

Model	<u>GD300-W</u>		<u>GD350@6-W</u>			
Frequency/Speed - Voltage	50HZ/1500 RPM-	230/400V	60HZ/1800 RPM-	277/480V	60HZ/1800 RPM- 230/400V	
Prime Power	300 KVA	240 KW	350 KVA	280 KW	337 KVA	270 KW
Standby Power	330 KVA	264 KW	385 KVA	308 KW	371 KVA	297 KW



Image for illustration purposes only.

Features

Engine	Doosan, P126T1-II, Made in Korea, complying to the norms: ISO 3046, ISO 8528 BS 5514 and DIN 6271
Alternator	WEG, AG10-250MI10AI, Made in Brazil, complying to the norms IEC 60034 - NBR 5117 - NEMA MG1 - VDE530 - ISO8528 - CSA
Control Panel	Deep sea, M-DCM-317B, Made in UK, complying to the norms BS EN 61000, BS EN 60950, BS EN 60068
Base Frame	Black steel with Anti-vibration pads, Built in fuel tank
Sound Proof Canopy	Modular SPC, Powder Coated, Extremely Durable, Designed to Reduce Sound Level with Maximum Service Accessibility and Minimum Foot Prints
Worldwide Support	Mets Energy Products are distributed through its PowerMets International Network For more information kindly check our website www.metsenergy.com

Rating Definitions and Conditions

Prime Rating	The power available for an unlimited hour usage with an average load factor of 80% of the published prime power over each 24 hours period. A 10 % overload is available for 1Hr every 12 hours.
Standby Rating	The power limited to 500 hours annual usage with an average load factor of 80% of the published standby power rating over each 24-hour period. Up to 300 hours of annual usage may be run continuously. No overload is permitted on standby power.
KVA Rating @ 0.8 P.F	

Due to continuous product development, we reserve the right to change specifications at any time without prior notice.

Rev0_GD300-W/350@6-W_150214

Engine Doosan, P126T1-II, 4 Stroke Cycle, Diesel

Structure	Number of Cylinders	6	
	Engine Build	In line	
	Bore	123	
	Stroke	155	
	Displacement	11.051 L	
	Compression Ratio	17 /1	
	Aspiration	turbocharged	
	Cooling	A/A	
Fuel	Fuel Tank	1500 rpm Built in fuel tank 295L for 5 hours operation @ full load	1800 rpm Built in fuel tank 295L for 4 hours operation @ full load
	Fuel System	Direct injection	
	Fuel Recommended	N°2 Diesel	
	Fuel System Make (ECM)	-	
		1500 rpm	1800 rpm
	Delivery Flow Rate (l/hr)	230	230
	Fuel Consumption		
	100% Load (g/kWh-L/hr)	TBA(63.1)	TBA(73.8)
	75% Load (g/kWh-L/hr)	TBA(47)	TBA(56)
	50% Load (g/kWh-L/hr)	TBA(31.3)	TBA(37)
Cooling system	Engine Coolant Capacity	50.5L	
	Air Flow-Radiator	7500 l/s	8833.3 l/s
	radiator with 50 degree ambient Cooling Package & Air Cleaner Kit Thermostatically-controlled system		
	Air Inlet	Air Intake Engine (Clean Filter/Dirty) 2.16/6.23 kPa	
Exhaust System	Exhaust Gas Temperature (Prime)	590 °C	500 °C
	Exhaust Gas Flow (Prime)	790 l/s	1026.7 l/s
	Maximum Exhaust System Back Pressure	5.9 kPa	5.9 kPa
	Muffler	residential (20→25 dB)	industrial(15→25 dB)
	Stainless Steel exhaust flex-fittings		
DC System-Starting/Charging	Cranking Battery Voltage	24 V	
	Battery Charging Alternator	45 A	
	Dc Voltage Monitoring via control panel		
Heat Rejection	Radiated Heat to Ambient (Prime)	22.6 kW	26.4 kW
	Heat Rejection to Coolant (Prime)	96.7 kW	113.1 kW
	Heat Rejection to Exhaust (Prime)	222.4 kW	260.1 kW
	Heat Rejection to After Cooler (prime)	51.6 kW	60.3 kW
Lube System	Lubricating System Oil Capacity	23 L	
Governor	Electronic		

Due to continuous product development, we reserve the right to change specifications at any time without prior notice.

Rev0_GD300-W/350@6-W_150214

Alternator Weg,AG10-250MI10AI

Structure	Insulation System	Class H	
	Winding Pitch	2/3 to minimize harmonics effects	
	Number of Poles	4	
	Number of Bearings	Single bearing	
	Winding Leads	12	
	Power Factor	0.8	
	Over Speed Capability (% of	2250 Rpm (125%)	
	Wave Form Distortion	THD(Total Harmonic Distortion)@ No load < 5.0%	
	Telephone Interference	TIF < 3%	
	IP Rating (Protection)	IP23	
	AVR	Excitation with auxiliary coil	
Synchronous, 3 phase, Brushless & Self ventilated			
		1500 rpm	1800 rpm
Power Switching	3-P Circuit Breaker, MCCB	630A	630A
Temperature	Temperature Rise	125/40 °C	
Control & Voltage Regulator	Control System (Standard)	Excitation with auxiliary coil	
	Voltage Regulator (AVR)	GRT7-TH4E(5A E9)	
	% Of Voltage Regulation	± 0.5 %	
Motor Starting Capacity@30% Voltage Dip	if voltage 230/400V	TBA	
	if voltage 277/480V	TBA	

Standard Controller, M-DCM-317B

Control	<ul style="list-style-type: none"> Auto/Start/Stop Control Emergency Stop Pushbutton/ Alarm Acknowledge Engine Cool Down Timer Warm-up Timer Load Switching Timer Engine Cycle Crank 	
Indications	<ul style="list-style-type: none"> Operating Hours 3 Phase Generator Voltage Sensing & Monitoring Current Protection & Monitoring Power Measurement (kW, kVA, kVA, kWh, kVAh, kVAh, pf) Frequency Monitoring (Hz) Oil Pressure/Coolant Temperature/Fuel Level Monitoring Battery Voltage Monitoring (DC) Alarm Acknowledge 	
Warning & Shutdown Alarms	<ul style="list-style-type: none"> Generator Over/Under Voltage & Frequency Crank Disconnect (Failure to Start) Under/Over Speed Over Current Low oil pressure High Water Temperature Low Fuel Level Low Water Level 	
Features	<ul style="list-style-type: none"> IP 65 (if ordered with gasket) Basic Scheduler 8-35 VDC Supply Digital Inputs(4)- Outputs(4 MPU/ 6 CAN) Event Log (5 shutdowns) 	
Optional Accessories		
Alternator	<ul style="list-style-type: none"> AVR (3 phase Sensing) Reactive Droop Winding Temperature Detectors Anti- Condensation Heaters Excitation with auxiliary exciter (PMG) 	
Power Switching	<ul style="list-style-type: none"> 4-P Circuit Breaker Special Brands (ABB- MG- Siemens...) Motorized Operation Shunt Trip Under Voltage Trip UVT Residual Current Protection Ground Fault Protection Earthing Kit Surge Arrestor 	

Optional Accessories (continues)

Engine	Fuel	Micro-Diesel Filter for Micro-Particles Filtration
		Automatic Fuel Refilling System
		Fuel Water Separat (2000/18)
		Mechanical Fuel Level Kit
		Oversize Fuel Tank Upon Custom Requirements
	Air Inlet	Fuel Tanks-Pipes Heater
		Sy-klone Air Cleaner Installed @ Air Intake System
	Exhaust	Muffler: Critical (25→30 dB) Hospital (35→40 dB)
		Elbow, Flanges, Expanders & Y Adaptors
	Cooling / Heating	Radiator with 35 °C or 60 °C Ambient Capability
Jacket Water Heater		
Lube	Manual Sump Drain Pump	
	Semi-Rotator Hand Pump	
DC System - Starting/Changing	Mains Battery Charger 24 V DC-5A	
	Battery Charger 10A-20A on Request	
	Automatic Battery Charger on Request	
	Battery Disconnect Switch	
	DC/AC Current Monitoring (Ammeter)	
Control Panel	Oversize Battery	
	DSE 7310/7320/7410/7420-More Inputs & Outputs-Advanced Communications Features;	
	DSE 8610/8710/8810- Load Share Module;	
	Digital & Analogues Inputs Module DSE 2130 (for 7000 Series & Above);	
	Analogue Inputs advanced Module DSE 2131-2133(for 7410 &Above);	
	Digital relay Outputs Module DSE 2157 (for 7000 Series &Above);	
	Analogue Outputs Module DSE 2152 (for 7410 & Above);	
	Local & Remote enunciator Module DSE 2548 (for 7000 Series & Above);	
	Display Modules DSE 2510/2520 (with 7310-7320);	
	Remote Monitoring via: Web Interface (All Series), GSM (for 7000 Series & Above), RS485 (for Dry Contacts Alarm Indication for Customer Use	
	Audible Alarm (Option for 6010/20; Standard for 7000 Series & Above);	
	Voltage Adjust Potentiometer;	
Speed Adjust Potentiometer;		

Dimensions & Weights

	Length (mm)	Width (mm)	Height (mm) "A"	Weight Dry
Open set (NB)	3000	1050	1556	2300
SPC Type S	TBA	TBA	TBA	TBA

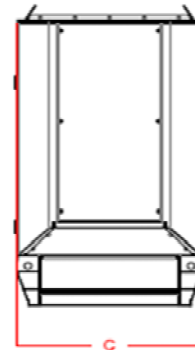
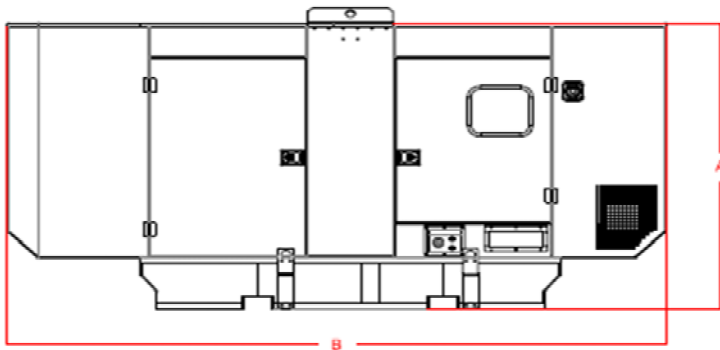
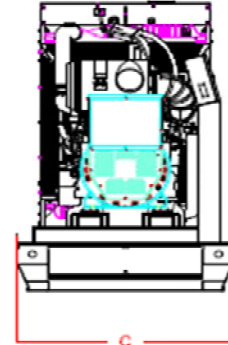
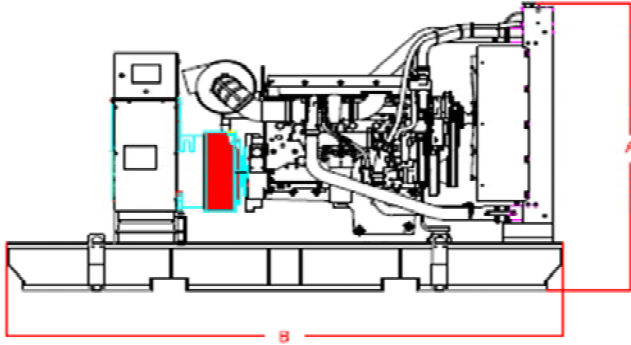

Drawings for illustration purposes only.

WWW.METSENERGY.com