



**METS ENERGY** S A L

Model	MP2-250-L		MP2-300@6-L			
Frequency/Speed - Voltage	50HZ/1500 RPM- 230/400V		60HZ/1800 RPM- 230/400V		60HZ/1800 RPM- 277/480V	
Prime Power	250 KVA	200 KW	265 KVA	212 KW	300 KVA	240 KW
Standby Power	275 KVA	220 KW	291.5 KVA	233.2 KW	330 KVA	264 KW



Image for illustration purposes only.

### Features

<b>Engine</b>	Perkins ,1506A-E88TAG3, Made in UK, in accordance to ISO3046 ,ISO8528,DIN6271
<b>Alternator</b>	LeRoySomer ,LSA46.2 L6 , Made in France, complying to the norms: IEC 60034, NEMA MG 1.22, ISO 8528/3, CSA, UL 1446, UL 1004B
<b>Control Panel</b>	Deep sea, M-DCM-317B ,Made in UK, complying to the norms: comply to the norms BS EN 61000, BS EN 60950, BS EN 60068
<b>Base Frame</b>	Black steel with Anti-vibration pads, Built in fuel tank
<b>Sound Proof Canopy</b>	Modular SPC, Powder Coated, Extremely Durable, Designed to Reduce Sound Level with Maximum Service Accessibility and Minimum Foot Prints
<b>Worldwide Support</b>	Mets Energy Products are distributed through its PowerMets International Network For more information kindly check our website <a href="http://www.metsenergy.com">www.metsenergy.com</a>

### Rating Definitions and Conditions

<b>Prime Rating</b>	The power available for an unlimited hour usage with an average load factor of 80% of the published prime power over each 24 hours period. A 10 % overload is available for 1Hr every 12 hours.
<b>Standby Rating</b>	The power limited to 500 hours annual usage with an average load factor of 80% of the published standby power rating over each 24-hour period. Up to 300 hours of annual usage may be run continuously. No overload is permitted on standby power.
	<b>KVA Rating @ 0.8 P.F</b>

Due to continuous product development, we reserve the right to change specifications at any time without prior notice.

Rev0\_MP2-250-L/MP2-300@6-L\_150213

**Engine Perkins, 1506A-E88TAG3, 4 Stroke Cycle, Diesel**

<b>Structure</b>	<b>Number of Cylinders</b>	6	
	<b>Engine Build</b>	In line	
	<b>Bore</b>	112 mm	
	<b>Stroke</b>	149 mm	
	<b>Displacement</b>	8.8 L	
	<b>Compression Ratio</b>	16.1:1	
	<b>Aspiration</b>	Turbocharged	
	<b>Cooling</b>	A /A	
<b>Fuel</b>	<b>Fuel Tank</b>	<b>1500 rpm</b> Built in fuel tank 445 for 9 hours operation @ full load	<b>1800 rpm</b> Built in fuel tank 445 L for 8 hours operation @ full load
	<b>Fuel System</b>	Direct injection	
	<b>Fuel Recommended</b>	N°2 Diesel	
	<b>Fuel System Make (ECM)</b>	-	
		<b>1500 rpm</b>	<b>1800 rpm</b>
	<b>Delivery Flow Rate (l/hr)</b>	TBA	TBA
	<b>Fuel Consumption</b>		
	<b>100% Load (g/kWh-L/hr)</b>	199 (56)	199 (63)
	<b>75% Load (g/kWh-L/hr)</b>	199 (42)	199 (48)
	<b>50% Load (g/kWh-L/hr)</b>	208 (29)	208 (33)
<b>Cooling system</b>	<b>Engine Coolant Capacity</b>		TBA
	<b>Air Flow-Radiator</b>	TBA	TBA
	radiator with 50 degree ambient capability Cooling Package & Air Cleaner Kit Thermostatically-controlled system		
<b>Air Inlet</b>	<b>Air Intake Engine</b> (Clean Filter/Dirty)	TBA	
<b>Exhaust System</b>	<b>Exhaust Gas Temperature (Prime)</b>	TBA	TBA
	<b>Exhaust Gas Flow (Prime)</b>	TBA	TBA
	<b>Maximum Exhaust System Back Pressure</b>	TBA	TBA
	<b>Muffler</b> residential (20→25 dB) industrial(15→25 dB) Stainless Steel exhaust flex-fittings		
<b>DC System-Starting/Charging</b>	<b>Cranking Battery Voltage</b>	TBA	
	<b>Battery Charging Alternator</b>	TBA	
Dc Voltage Monitoring via control panel			
<b>Heat Rejection(prime)</b>	<b>Radiated Heat to Ambient (Prime)</b>	TBA	TBA
	<b>Heat Rejection to Coolant (Prime)</b>	TBA	TBA
	<b>Heat Rejection to Exhaust (Prime)</b>	TBA	TBA
	<b>Heat Rejection to intercooler (prime)</b>	TBA	TBA
<b>Lube System</b>	<b>Lubricating System Oil Capacity</b>	41 L	
<b>Governor</b>	Mechanical		



**METS ENERGY** S A L

**Alternator, LSA46.2 L6**

<b>Structure</b>	<b>Insulation System</b>	Class H	
	<b>Winding Pitch</b>	2/3 to minimize harmonics effects	
	<b>Number of Poles</b>	4	
	<b>Number of Bearings</b>	Single bearing	
	<b>Winding Leads</b>	12	
	<b>Power Factor</b>	0.8	
	<b>Over Speed Capability (% of</b>	2250 Rpm (150%)	
	<b>Wave Form Distortion</b>	no load < 3% - on load < 2%	
	<b>Telephone Interference</b>	TIF< 50	
	<b>IP Rating (Protection)</b>	IP23	
<b>AVR</b>	SHUNT (12 wire)		
	Synchronous, 3 phase, Brushless & Self ventilated		
		<b>1500 rpm</b>	<b>1800 rpm</b>
<b>Power Switching</b>	3-P Circuit Breaker, MCCB	400A	630A
<b>Temperature</b>	<b>Temperature Rise</b>	125/40 °C	
<b>Control &amp; Voltage Regulator</b>	<b>Control System (Standard)</b>	SHUNT (12 wire)	
	<b>Voltage Regulator (AVR)</b>	R 250	
	<b>% Of Voltage Regulation</b>	± 0,5 %	
<b>Motor Starting Capacity@30%</b>	if voltage 230/400V	TBA	
<b>Voltage Dip</b>	if voltage 277/480V	TBA	

### Standard Controller, M-DCM-317D

<b>Control</b>	<ul style="list-style-type: none"> <li>Fuel tank monitoring</li> <li>Emergency Stop Pushbutton/ Alarm Acknowledge</li> <li>Engine Cool Down Timer</li> <li>Warm-up Timer</li> <li>Load Switching Timer</li> <li>Engine Cycle Crank</li> </ul>	
<b>Indications</b>	<ul style="list-style-type: none"> <li>Operating Hours</li> <li>3 Phase Generator Voltage Sensing &amp; Monitoring</li> <li>Current Protection &amp; Monitoring</li> <li>Power Measurement (kW, kVA, kVAR, kWh, kVAh, kVArh, pf)</li> <li>Frequency Monitoring (Hz)</li> <li>Oil Pressure/Coolant Temperature/Fuel Level Monitoring</li> <li>Battery Voltage Monitoring (DC)</li> <li>Alarm Acknowledge</li> </ul>	
<b>Warning &amp; Shutdown Alarms</b>	<ul style="list-style-type: none"> <li>Generator Over/Under Voltage &amp; Frequency</li> <li>Crank Disconnect (Failure to Start)</li> <li>Under/Over Speed</li> <li>Over Current</li> <li>Low oil pressure</li> <li>High Water Temperature</li> <li>Low Fuel Level</li> <li>Low Water Level</li> </ul>	
<b>Features</b>	<ul style="list-style-type: none"> <li>IP 65 (if ordered with gasket)</li> <li>Basic Scheduler</li> <li>8-35 VDC Supply</li> <li>Digital Inputs(4)- Outputs(4 MPU/ 6 CAN)</li> <li>Event Log (5 shutdowns)</li> </ul>	

### Optional Accessories

<b>Alternator</b>	<ul style="list-style-type: none"> <li>AVR (3 phase Sensing)</li> <li>Reactive Droop</li> <li>Winding Temperature Detectors</li> <li>Anti- Condensation Heaters</li> <li>Excitation with auxiliary exciter (PMG)</li> </ul>
<b>Power Switching</b>	<ul style="list-style-type: none"> <li>4-P Circuit Breaker</li> <li>Special Brands (ABB- MG- Siemens...)</li> <li>Motorized Operation</li> <li>Shunt Trip</li> <li>Under Voltage Trip UVT</li> <li>Residual Current Protection</li> <li>Ground Fault Protection</li> <li>Earthing Kit</li> <li>Surge Arrestor</li> </ul>

**Optional Accessories** (continues)

	<b>Fuel</b>	Micro-Diesel Filter for Micro-Particles Filtration Automatic Fuel Refilling System Fuel Water Separator <b>(2000/10)</b> Mechanical Fuel Level Kit Oversize Fuel Tank Upon Custom Requirements Fuel Tanks-Pipes Heater
<b>Engine</b>	<b>Air Inlet</b>	Sy-klone Air Cleaner Installed @ Air Intake System
	<b>Exhaust</b>	Muffler: Critical (25→30 dB) Hospital (35→40 dB) Elbow, Flanges, Expanders & Y Adaptors
	<b>Cooling / Heating</b>	Radiator with 35 °C or 60 °C Ambient Capability Jacket Water Heater
	<b>Lube</b>	Manual Sump Drain Pump Semi-Rotator Hand Pump
	<b>DC System - Starting/Changing</b>	Mains Battery Charger 24 V DC-5A Battery Charger 10A-20A on Request Automatic Battery Charger on Request Battery Disconnect Switch DC/AC Current Monitoring (Ammeter) Oversize Battery
<b>Control Panel</b>	DSE 7310/7320/7410/7420-More Inputs & Outputs-Advanced Communications Features; DSE 8610/8710/8810- Load Share Module; Digital & Analogues Inputs Module DSE 2130 (for 7000 Series & Above); Analogue Inputs advanced Module DSE 2131-2133(for 7410 &Above); Digital relay Outputs Module DSE 2157 (for 7000 Series &Above); Analogue Outputs Module DSE 2152 (for 7410 & Above); Local & Remote enunciator Module DSE 2548 (for 7000 Series & Above); Display Modules DSE 2510/2520 (with 7310-7320); Remote Monitoring via: Web Interface (All Series), GSM (for 7000 Series & Above), RS485 (for 7000 Dry Contacts Alarm Indication for Customer Use Audible Alarm (Option for 6010/20; Standard for 7000 Series & Above); Voltage Adjust Potentiometer; Speed Adjust Potentiometer;	

**Dimensions & Weights**

	Length (mm)	Width (mm)	Height (mm)	Weight Dry
Open set (NB)	2720	1210	1794	1852
SPC Type S	4280	1210	2136	2675

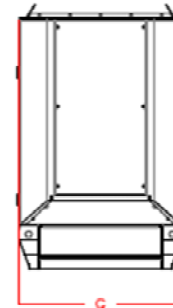
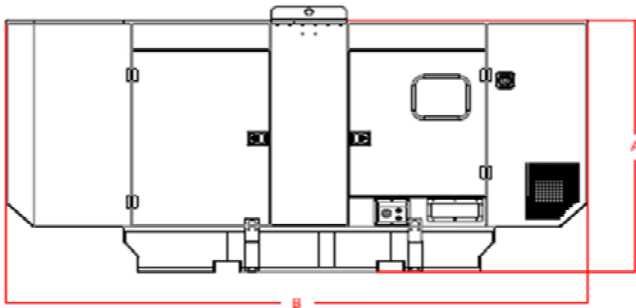
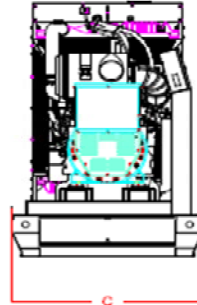
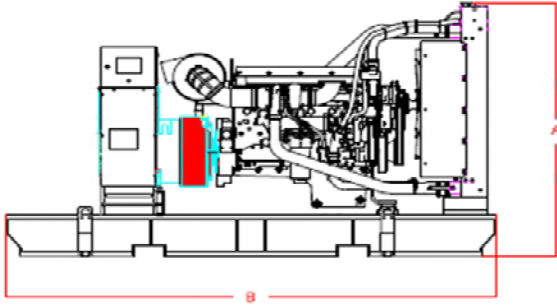

Drawings for illustration purposes only.

[WWW.METSENERGY.com](http://WWW.METSENERGY.com)