



METS ENERGY S A L

Model	MP650-L		MP625@6-2-L			
Frequency/Speed - Voltage	50HZ/1500 RPM- 230/400V		60HZ/1800 RPM- 230/400V		60HZ/1800 RPM- 277/480V	
Prime Power	650 KVA	520 KW	625 KVA	500 KW	625 KVA	500 KW
Standby Power	715 KVA	572 KW	687 KVA	550 KW	687 KVA	550 KW



Image for illustration purposes only.

Features

Engine	Perkins ,2806A-E18TAG2 , Made in UK, in accordance to ISO3046 ,ISO8528,DIN6271
Alternator	LeRoySomer ,LSA49.1 S4 , Made in France, complying to the norms: IEC 60034, NEMA MG 1.22, ISO 8528/3, CSA, UL 1446, UL 1004B
Control Panel	Deep sea, M-DCM-317B ,Made in UK, complying to the norms: comply to the norms BS EN 61000, BS EN 60950, BS EN 60068
Base Frame	Black steel with Anti-vibration pads, Built in fuel tank
Sound Proof Canopy	Modular SPC, Powder Coated, Extremely Durable, Designed to Reduce Sound Level with Maximum Service Accessibility and Minimum Foot Prints
Worldwide Support	Mets Energy Products are distributed through its PowerMets International Network For more information kindly check our website www.metsenergy.com

Rating Definitions and Conditions

Prime Rating	The power available for an unlimited hour usage with an average load factor of 80% of the published prime power over each 24 hours period. A 10 % overload is available for 1Hr every 12 hours.
Standby Rating	The power limited to 500 hours annual usage with an average load factor of 80% of the published standby power rating over each 24-hour period. Up to 300 hours of annual usage may be run continuously. No overload is permitted on standby power. KVA Rating @ 0.8 P.F

Due to continuous product development, we reserve the right to change specifications at any time without prior notice.

Rev0_MP650-L/MP625@6-2-L_150331



METS ENERGY

Engine Perkins, 2806A-E18TAG1A , 4 Stroke Cycle, Diesel

Structure	Number of Cylinders	6	
	Engine Build	In line	
	Bore	145 mm	
	Stroke	183 mm	
	Displacement	18.1 L	
	Compression Ratio	14.5 /1	
	Aspiration	Turbocharged	
	Cooling	A /A	
Fuel	Fuel Tank	1500 rpm Built in fuel tank 972 for 8h hours operation @ full load	1800 rpm Built in fuel tank 972 for 8h hours operation @ full load
	Fuel System		Direct injection
	Fuel Recommended		N°2 Diesel
	Fuel System Make (ECM)		-
	Delivery Flow Rate (l/hr)	1500 rpm TBA	1800 rpm TBA
	Fuel Consumption		
	100% Load (g/kWh-L/hr)	202 (123)	202 (127)
	75% Load (g/kWh-L/hr)	198 (97)	201 (95)
	50% Load (g/kWh-L/hr)	201 (66)	203 (61)
		Engine Coolant Capacity	61 L
Cooling system	Air Flow-Radiator	11700 l/s	14200 l/s
	radiator with 50 degree ambient capability Cooling Package & Air Cleaner Kit Thermostatically-controlled system		
	Air Inlet	Air Intake Engine (Clean Filter/Dirty)	3.7 /6.4 kPa
Exhaust System	Exhaust Gas Temperature (Prime)	568 °C	481 °C
	Exhaust Gas Flow (Prime)	1600 l/s	1816.6 l/s
	Maximum Exhaust System Back Pressure	6.9 kPa	6.9 kPa
	Muffler	residential (20→25 dB)	industrial(15→25 dB)
DC System-Starting/Charging	Stainless Steel exhaust flex-fittings		
	Cranking Battery Voltage		24 V
	Battery Charging Alternator		70 A
Heat Rejection(Prime)	Dc Voltage Monitoring via control panel		
	Radiated Heat to Ambient (Prime)	41 kW	40 kW
	Heat Rejection to Coolant (Prime)	202 kW	166 kW
	Heat Rejection to Exhaust (Prime)	447 kW	441 kW
	Heat Rejection to intercooler (prime)	100 kW	113 kW
Lube System	Lubricating System Oil Capacity	62 L	
Governor	Electronic		

Due to continuous product development, we reserve the right to change specifications at any time without prior notice.

Rev0_MP650-L/MP625@6-2-L_150331



METS ENERGY S A L

Alternator, LSA49.1 S4

Structure	Insulation System	Class H	
	Winding Pitch	2/3 to minimize harmonics effects	
	Number of Poles	4	
	Number of Bearings	Single bearing	
	Winding Leads	12	
	Power Factor	0.8	
	Over Speed Capability (% of	2250 Rpm (150%)	
	Wave Form Distortion	no load < 3% - on load < 2%	
	Telephone Interference	TIF< 50	
	IP Rating (Protection)	IP23	
AVR	SHUNT (12 wire)		
Synchronous, 3 phase, Brushless & Self ventilated			
		1500 rpm	1800 rpm
Power Switching	3-P Circuit Breaker, MCCB	1000A	1000A
Temperature	Temperature Rise	125/40 °C	
Control & Voltage Regulator	Control System (Standard)	SHUNT (12 wire)	
	Voltage Regulator (AVR)	R 250	
	% Of Voltage Regulation	± 0,5 %	
Motor Starting Capacity@30%	if voltage 230/400V	TBA	
Voltage Dip	if voltage 277/480V	TBA	

Standard Controller, M-DCM-317

Control	<ul style="list-style-type: none"> Fuel tank monitoring Emergency Stop Pushbutton/ Alarm Acknowledge Engine Cool Down Timer Warm-up Timer Load Switching Timer Engine Cycle Crank 	
Indications	<ul style="list-style-type: none"> Operating Hours 3 Phase Generator Voltage Sensing & Monitoring Current Protection & Monitoring Power Measurement (kW, kVA, kVA_r, kWh, kVAh, kVA_rh, pf) Frequency Monitoring (Hz) Oil Pressure/Coolant Temperature/Fuel Level Monitoring Battery Voltage Monitoring (DC) Alarm Acknowledge 	
Warning & Shutdown Alarms	<ul style="list-style-type: none"> Generator Over/Under Voltage & Frequency Crank Disconnect (Failure to Start) Under/Over Speed Over Current Low oil pressure High Water Temperature Low Fuel Level Low Water Level 	
Features	<ul style="list-style-type: none"> IP 65 (if ordered with gasket) Basic Scheduler 8-35 VDC Supply Digital Inputs(4)- Outputs(4 MPU/ 6 CAN) Event Log (5 shutdowns) 	

Optional Accessories

Alternator	<ul style="list-style-type: none"> AVR (3 phase Sensing) Reactive Droop Winding Temperature Detectors Anti- Condensation Heaters Excitation with auxiliary exciter (PMG)
Power Switching	<ul style="list-style-type: none"> 4-P Circuit Breaker Special Brands (ABB- MG- Siemens...) Motorized Operation Shunt Trip Under Voltage Trip UVT Residual Current Protection Ground Fault Protection Earthing Kit Surge Arrestor



Optional Accessories^(continues)

	<ul style="list-style-type: none"> Micro-Diesel Filter for Micro-Particles Filtration Automatic Fuel Refilling System Fuel Water Separator (2000/40) Mechanical Fuel Level Kit Oversize Fuel Tank Upon Custom Requirements Fuel Tanks-Pipes Heater 	
Engine	Air Inlet	Sy-klone Air Cleaner Installed @ Air Intake System
	Exhaust	Muffler: Critical (25→30 dB) Hospital (35→40 dB)
		Elbow, Flanges, Expanders & Y Adaptors
	Cooling / Heating	Radiator with 35 °C or 60 °C Ambient Capability
		Jacket Water Heater
	Lube	Manual Sump Drain Pump
Semi-Rotator Hand Pump		
DC System - Starting/Changing	Mains Battery Charger 24 V DC-5A	
	Battery Charger 10A-20A on Request	
	Automatic Battery Charger on Request	
	Battery Disconnecter Switch	
	DC/AC Current Monitoring (Ammeter)	
	Oversize Battery	
Control Panel	DSE 7310/7320/7410/7420-More Inputs & Outputs-Advanced Communications Features;	
	DSE 8610/8710/8810- Load Share Module;	
	Digital & Analogues Inputs Module DSE 2130 (for 7000 Series & Above);	
	Analogue Inputs advanced Module DSE 2131-2133(for 7410 &Above);	
	Digital relay Outputs Module DSE 2157 (for 7000 Series &Above);	
	Analogue Outputs Module DSE 2152 (for 7410 & Above);	
	Local & Remote enunciator Module DSE 2548 (for 7000 Series & Above);	
	Display Modules DSE 2510/2520 (with 7310-7320);	
	Remote Monitoring via: Web Interface (All Series), GSM (for 7000 Series & Above), RS485 (for 7000	
	Dry Contacts Alarm Indication for Customer Use	
Audible Alarm (Option for 6010/20; Standard for 7000 Series & Above);		
Voltage Adjust Potentiometer;		
Speed Adjust Potentiometer;		



METS ENERGY S A L

Dimensions & Weights

	Length (mm)	Width (mm)	Height (mm)	Weight Dry
Open set (NB)	3310	1550	2098	4787
SPC Type S	5800	2000	2350	6883

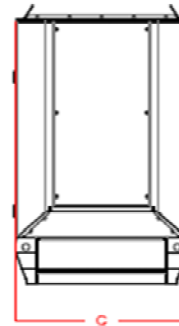
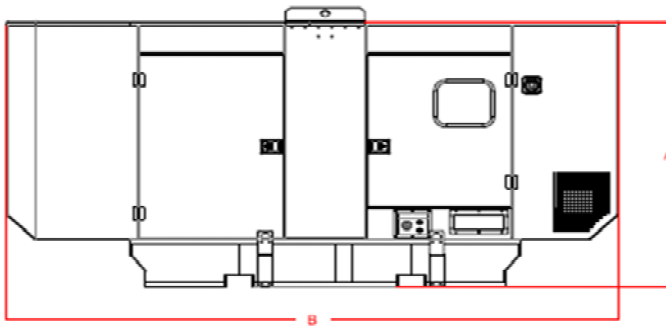
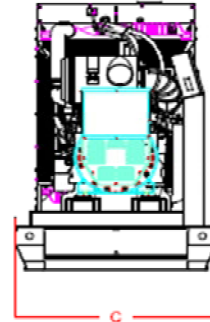
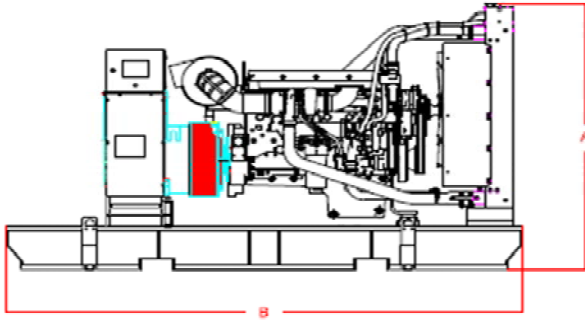

Drawings for illustration purposes only.

WWW.METSENERGY.com