



METS ENERGY S A L

Model	MP13-M		MP16@6-M			
Frequency/Speed - Voltage	50HZ/1500 RPM- 230/400V		60HZ/1800 RPM- 230V/400V		60HZ/1800 RPM- 277V/480V	
Prime Power	12.5 KVA	10 KW	13.5 KVA	10.8 KW	15 KVA	12 KW
Standby Power	13.75 KVA	11 KW	14.86 KVA	11.88 KW	16.5 KVA	13.2 KW



Image for illustration purposes only.

Features

Engine	Perkins , 403-15G1 , Made in UK, in accordance to ISO3046 ,ISO8528,DIN6271
Alternator	Meccalte, ECP3 -2L/4 or ECP28-OS/4 , Made in UK, complying to the following norms:CEE/ CEI2-3/ EN60034-1/ IEC34-1/ VDE/ BS/ CAN/ CSA
Control Panel	Deep sea, M-DCM-317 ,Made in UK, complying to the norms: comply to the norms BS EN 61000, BS EN 60950, BS EN 60068
Base Frame	Black steel with Anti-vibration pads, Built in fuel tank
Sound Proof Canopy	Modular SPC, Powder Coated, Extremely Durable, Designed to Reduce Sound Level with Maximum Service Accessibility and Minimum Foot Prints
Worldwide Support	Mets Energy Products are distributed through its PowerMets International Network For more information kindly check our website www.metsenergy.com

Rating Definitions and Conditions

Prime Rating	The power available for an unlimited hour usage with an average load factor of 80% of the published prime power over each 24 hours period. A 10 % overload is available for 1Hr every 12 hours.
Standby Rating	The power limited to 500 hours annual usage with an average load factor of 80% of the published standby power rating over each 24-hour period. Up to 300 hours of annual usage may be run continuously. No overload is permitted on standby power.

Due to continuous product development, we reserve the right to change specifications at any time without prior notice.

Rev0_MP13-M,MP16@6-M_150226



Engine Perkins, 403-15G1, 4 Stroke Cycle, Diesel

Structure	Number of Cylinders	3	
	Engine Build	In line	
	Bore	84 mm	
	Stroke	90 mm	
	Displacement	1.496 L	
	Compression Ratio	22.5/1	
	Aspiration	Natural	
	Cooling	Water cooled	
Fuel	Fuel Tank	1500 RPM Built in fuel tank 27 L for 7 hours operation @ full load	1800 RPM Built in fuel tank 27 L for 7 hours operation @ full load
	Fuel System		Direct injection
	Fuel Recommended		N°2 Diesel
	Fuel System Make (ECM)		-
		1500 rpm	1800 RPM
	Delivery Flow Rate (l/hr)		
	Fuel Consumption		
	100% Load (g/kWh-L/hr)	248(3.7)	TBA
	75% Load (g/kWh-L/hr)	252 (2.8)	TBA
	50% Load (g/kWh-L/hr)	277 (2)	TBA
Cooling system	Engine Coolant Capacity		6L
	Air Flow-Radiator	420 l/s	TBA
	radiator with 50 degree ambient Cooling Package & Air Cleaner Thermostatically-controlled		
	Air Inlet	Air Intake Engine(Clean Filter/Dirty)	3 / 6.4 KPa
Exhaust System	Exhaust Gas Temperature	445 °C	TBA
	Exhaust Gas Flow (Prime)	45.3 l/s	TBA
	Maximum Exhaust System Back Pressure	10.2 kPa	TBA
	Muffler	residential (20→25 dB)	industrial(15→25 dB)
	Stainless Steel exhaust flex-		
DC System-Starting/Charging	Cranking Battery Voltage		12 V
	Battery Charging Alternator		65 A
	Dc Voltage Monitoring via		
Heat Rejection(prime)	Radiated Heat to Ambient	3.2 KW	TBA
	Heat Rejection to Coolant	11.6 KW	TBA
	Heat Rejection to Exhaust	9.3 KW	TBA
	Heat Rejection to intercooler	0	TBA
Lube System	Lubricating System Oil Capacity		6 L
Governor	Mechanical		



METS ENERGY S A L

Alternator Meccalte , ECP3 -2L/4 or ECP28-OS/4

Structure	Insulation System	Class H	
	Winding Pitch	2/3 to minimize harmonics effects	
	Number of Poles	4	
	Number of Bearings	Single bearing	
	Winding Leads	12	
	Power Factor	0.8	
	Over Speed Capability (% of	2250 Rpm (150%)	
	Wave Form Distortion	2.3/2 % @ full Load , 2.6/2.6% @ no Load	
	Telephone Interference	THF< 2%	
	IP Rating (Protection)	IP23(other Protection on request)	
	AVR	DSR (1-phase sensing/ additional equipment for 3-phase sensing)	
		Synchronous, 3 phase, Brushless & Self ventilated	
		1500	1800
Power Switching	3-P/2-P Circuit Breaker, mcb	20A	20A
Temperature	Temperature Rise	125/40 °C	
Control & Voltage Regulator	Control System (Standard)	MAUX excitation	
	Voltage Regulator (AVR)	DSR (1-phase sensing/ additional equipment for 3-phase	
	% Of Voltage Regulation	± 1.0 %	
Motor Starting Capacity@30%	if voltage 230/400V	TBA	
Voltage Dip	if voltage 277/480V	TBA	

Due to continuous product development, we reserve the right to change specifications at any time without prior notice.

Rev0_MP13-M,MP16@6-M_150226

Standard Controller, M-DCM-317

Control	<ul style="list-style-type: none"> Fuel tank monitoring Emergency Stop Pushbutton/ Alarm Acknowledge Engine Cool Down Timer Warm-up Timer Load Switching Timer Engine Cycle Crank 	
Indications	<ul style="list-style-type: none"> Operating Hours 3 Phase Generator Voltage Sensing & Monitoring Current Protection & Monitoring Power Measurement (kW, kVA, kVAR, kWh, kVAh, kVAh, pf) Frequency Monitoring (Hz) Oil Pressure/Coolant Temperature/Fuel Level Monitoring Battery Voltage Monitoring (DC) Alarm Acknowledge 	
Warning & Shutdown Alarms	<ul style="list-style-type: none"> Generator Over/Under Voltage & Frequency Crank Disconnect (Failure to Start) Under/Over Speed Over Current Low oil pressure High Water Temperature Low Fuel Level Low Water Level 	
Features	<ul style="list-style-type: none"> IP 65 (if ordered with gasket) Basic Scheduler 8-35 VDC Supply Digital Inputs(4)- Outputs(4 MPU/ 6 CAN) Event Log (5 shutdowns) 	

Optional Accessories

Alternator	<ul style="list-style-type: none"> AVR (3 phase Sensing) Reactive Droop Winding Temperature Detectors Anti- Condensation Heaters Excitation with auxiliary exciter
Power Switching	<ul style="list-style-type: none"> 4-P Circuit Breaker Special Brands (ABB- MG- Motorized Operation Shunt Trip Under Voltage Trip UVT Residual Current Protection Ground Fault Protection Earthing Kit Surge Arrestor

Optional Accessories (continues)

Engine	Fuel	Micro-Diesel Filter for Micro-Particles Filtration Automatic Fuel Refilling System Fuel Water Separator (2000/5) Mechanical Fuel Level Kit Oversize Fuel Tank Upon Custom Requirements Fuel Tanks-Pipes Heater Optional Built in fuel tank 62 L operation full load (Height will be increased by 100 mm and weight by
	Air Inlet	Sy-klone Air Cleaner Installed @ Air Intake System
	Exhaust	Muffler: Critical (25→30 dB) Hospital (35→40 dB) Elbow, Flanges, Expanders & Y Adaptors
	Cooling / Heating	Radiator with 35 °C or 60 °C Ambient Capability Jacket Water Heater
	Lube	Manual Sump Drain Pump Semi-Rotator Hand Pump
	DC System - Starting/Changing	Mains Battery Charger 24 V DC-5A Battery Charger 10A-20A on Request Automatic Battery Charger on Request Battery Disconnect Switch DC/AC Current Monitoring (Ammeter) Oversize Battery
	Control Panel	DSE 7310/7320/7410/7420-More Inputs & Outputs-Advanced Communications DSE 8610/8710/8810- Load Share Module; Digital & Analogues Inputs Module DSE 2130 (for 7000 Series & Above); Analogue Inputs advanced Module DSE 2131-2133(for 7410 &Above); Digital relay Outputs Module DSE 2157 (for 7000 Series &Above); Analogue Outputs Module DSE 2152 (for 7410 & Above); Local & Remote enunciator Module DSE 2548 (for 7000 Series & Above); Display Modules DSE 2510/2520 (with 7310-7320); Remote Monitoring via: Web Interface (All Series), GSM (for 7000 Series & Above), Dry Contacts Alarm Indication for Customer Use Audible Alarm (Option for 6010/20; Standard for 7000 Series & Above); Voltage Adjust Potentiometer; Speed Adjust Potentiometer;

Dimensions & Weights

	Length (mm)	Width (mm)	Height (mm)	Weight Dry
Open set (NB)	1500	760	1070	475
SPC Type S	2200	950	1300	750

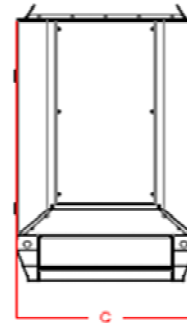
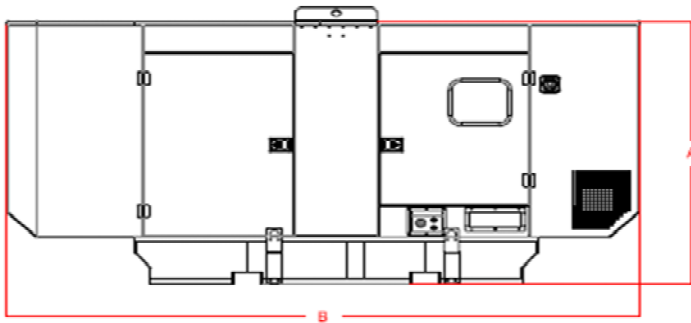
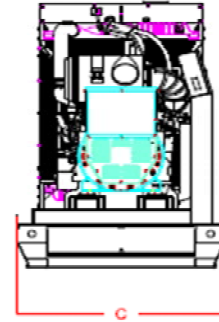
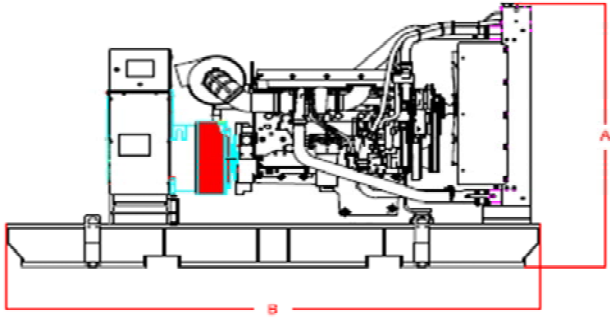

Drawings for illustration purposes only.

WWW.METSENERGY.com