



**METS ENERGY** S.A.L

Model	NA		MP1250B@6-2-S			
Frequency/Speed - Voltage	50HZ/1500 RPM- 230/400V		60HZ/1800 RPM- 230/400V		60HZ/1800 RPM- 277/480V	
Prime Power	NA	NA	1250 KVA	1000 KW	1250 KVA	1000 KW
Standby Power	NA	NA	1375 KVA	1100 KW	1375 KVA	1100 KW



Image for illustration purposes only.

## Features

<b>Engine</b>	Perkins ,4012-46TWG2A , Made in UK, in accordance to ISO3046 ,ISO8528,DIN6271
<b>Alternator</b>	Stamford PI734A , Made in UK, complying to the norms: BS EN60034/ BS 5000/ VDE 0530/ NEMA MG 1-32/ IEC 34/ CSA C22.2-100/ AS 1359
<b>Control Panel</b>	Deap sea, M-DCM-417(7320) ,Made in UK, complying to the norms: BS EN60034/ BS 5000/ VDE 0530/ NEMA MG 1-32/ IEC 34/ CSA C22.2-100/ AS 1359
<b>Base Frame</b>	Black steel with Anti-vibration pads, Built in fuel tank
<b>Sound Proof Canopy</b>	Modular SPC, Powder Coated, Extremely Durable, Designed to Reduce Sound Level with Maximum Service Accessibility and Minimum Foot Prints
<b>Worldwide Support</b>	Mets Energy Products are distributed through its PowerMets International Network For more information kindly check our website <a href="http://www.metsenergy.com">www.metsenergy.com</a>

## Rating Definitions and Conditions

<b>Prime Rating</b>	The power available for an unlimited hour usage with an average load factor of 80% of the published prime power over each 24 hours period. A 10 % overload is available for 1Hr every 12 hours.
<b>Standby Rating</b>	The power limited to 500 hours annual usage with an average load factor of 80% of the published standby power rating over each 24-hour period. Up to 300 hours of annual usage may be run continuously. No overload is permitted on standby power.
	<b>KVA Rating @ 0.8 P.F</b>

Due to continuous product development, we reserve the right to change specifications at any time without prior notice.

Rev0\_MP1250B@6-2-S\_150401



**METS ENERGY** S A L

**Engine Perkins, 4012-46TWG2A, 4 Stroke Cycle, Diesel**

<b>Structure</b>	<b>Number of Cylinders</b>	12		
	<b>Engine Build</b>	60 ° V		
	<b>Bore</b>	160 mm		
	<b>Stroke</b>	190 mm		
	<b>Displacement</b>	45.842 L		
	<b>Compression Ratio</b>	13.6 /1		
	<b>Aspiration</b>	Turbocharged		
	<b>Cooling</b>	A /A		
<b>Fuel</b>	<b>Fuel Tank</b>	<b>1500 rpm</b>	<b>1800 rpm</b>	
		NA	NA	
	<b>Fuel System</b>	Direct injection		
	<b>Fuel Recommended</b>	N°2 Diesel		
	<b>Fuel System Make (ECM)</b>	-		
		<b>1500 rpm</b>	<b>1800 rpm</b>	
	<b>Delivery Flow Rate (l/hr)</b>			
	<b>Fuel Consumption</b>			
	<b>100% Load (g/kWh-L/hr)</b>	NA	217 (266)	
	<b>75% Load (g/kWh-L/hr)</b>	NA	NA	
<b>50% Load (g/kWh-L/hr)</b>	NA	NA		
<b>Cooling system</b>	<b>Engine Coolant Capacity</b>		225 L	
	<b>Air Flow-Radiator</b>	NA	TBA	
	radiator with 50 degree ambient Cooling Package & Air Cleaner Kit			
	Thermostatically-controlled system			
<b>Air Inlet</b>	<b>Air Intake Engine(Clean Filter/Dirty)</b>	2 / 4 kPa		
<b>Exhaust System</b>	<b>Exhaust Gas Temperature (Prime)</b>	NA	TBA	
	<b>Exhaust Gas Flow (Prime)</b>	NA	TBA	
	<b>Maximum Exhaust System Back Pressure</b>	NA	TBA	
	<b>Muffler</b>	residential (20→25 dB)	industrial(15→25 dB)	
	Stainless Steel exhaust flex-fittings			
<b>DC System-Starting/Charging</b>	<b>Cranking Battery Voltage</b>		24 V	
	<b>Battery Charging Alternator</b>		40 A	
	Dc Voltage Monitoring via control panel			
<b>Heat Rejection(prime)</b>	<b>Radiated Heat to Ambient (Prime)</b>	NA	TBA	
	<b>Heat Rejection to Coolant (Prime)</b>	NA	TBA	
	<b>Heat Rejection to Exhaust (Prime)</b>	NA	TBA	
	<b>Heat Rejection to intercooler (prime)</b>	NA	TBA	
<b>Lube System</b>	<b>Lubricating System Oil Capacity</b>		177.6 L	
<b>Governor</b>	Electronic			

Due to continuous product development, we reserve the right to change specifications at any time without prior notice.

Rev0\_MP1250B@6-2-S\_150401



**METS ENERGY** S A L

**Alternator Stamford, PI734A**

<b>Structure</b>	<b>Insulation System</b>	Class H	
	<b>Winding Pitch</b>	2/3 to minimize harmonics effects	
	<b>Number of Poles</b>	4	
	<b>Number of Bearings</b>	Single bearing	
	<b>Winding Leads</b>	6	
	<b>Power Factor</b>	0.8	
	<b>Over Speed Capability (% of Rated)</b>	2250 Rpm (150%)	
	<b>Wave Form Distortion</b>	No load < 1.5% Non-Distorting balanced linear load < 5.0%	
	<b>Telephone Interference</b>	THF< 2%	
	<b>IP Rating (Protection)</b>	IP23	
	<b>AVR</b>	Separately excited by PMG	
		Synchronous, 3 phase, Brushless & Self ventilated	
		<b>1500 rpm</b>	<b>1800 rpm</b>
<b>Power Switching</b>	3-P Circuit Breaker, ACB	NA	2000A
<b>Temperature</b>	<b>Temperature Rise</b>	125/40 °C	
<b>Control &amp; Voltage Regulator</b>	<b>Control System (Standard)</b>	Separately excited by PMG	
	<b>Voltage Regulator (AVR)</b>	MX321(3 phase sensing) or MX341(1 phase sensing)	
	<b>% Of Voltage Regulation</b>	± 0.5 % (for MX321) / ± 1.0 %(for MX341)	
<b>Motor Starting Capacity@30%</b>	if voltage 230/400V	TBA	
<b>Voltage Dip</b>	if voltage 277/480V	TBA	

Due to continuous product development, we reserve the right to change specifications at any time without prior notice.

Rev0\_MP1250B@6-2-S\_150401

**Standard Controller, M-DCM-417(7320)**

<b>Control</b>	<ul style="list-style-type: none"> <li>Auto/Start/Stop Control</li> <li>Emergency Stop Pushbutton/ Alarm Acknowledge</li> <li>Engine Cool Down Timer</li> <li>Warm-up Timer</li> <li>Load Switching Timer</li> <li>Engine Cycle Crank</li> </ul>	
<b>Indications</b>	<ul style="list-style-type: none"> <li>Operating Hours</li> <li>3 Phase Generator Voltage Sensing &amp; Monitoring</li> <li>Current Protection &amp; Monitoring</li> <li>Power Measurement (kW, kVA, kVA<sub>r</sub>, kWh, kVAh, kVA<sub>r</sub>h, pf)</li> <li>Frequency Monitoring (Hz)</li> <li>Oil Pressure/Coolant Temperature/Fuel Level Monitoring</li> <li>Battery Voltage Monitoring (DC)</li> <li>Alarm Acknowledge</li> </ul>	
<b>Warning &amp; Shutdown Alarms</b>	<ul style="list-style-type: none"> <li>Generator Over/Under Voltage &amp; Frequency</li> <li>Crank Disconnect (Failure to Start)</li> <li>Under/Over Speed</li> <li>Over Current</li> <li>Low oil pressure</li> <li>High Water Temperature</li> <li>Low Fuel Level</li> <li>Low Water Level</li> </ul>	
<b>Features</b>	<ul style="list-style-type: none"> <li>IP 65 (if ordered with gasket)</li> <li>Basic Scheduler</li> <li>8-35 VDC Supply</li> <li>Digital Inputs(4)- Outputs(4 MPU/ 6 CAN)</li> <li>Event Log (5 shutdowns)</li> </ul>	
<b>Optional Accessories</b>		
<b>Alternator</b>	<ul style="list-style-type: none"> <li>AVR (3 phase Sensing)</li> <li>Reactive Droop</li> <li>Winding Temperature Detectors</li> <li>Anti- Condensation Heaters</li> <li>Excitation with auxiliary exciter (PMG)</li> </ul>	
<b>Power Switching</b>	<ul style="list-style-type: none"> <li>4-P Circuit Breaker</li> <li>Special Brands (ABB- MG- Siemens...)</li> <li>Motorized Operation</li> <li>Shunt Trip</li> <li>Under Voltage Trip UVT</li> <li>Residual Current Protection</li> <li>Ground Fault Protection</li> <li>Earthing Kit</li> <li>Surge Arrestor</li> </ul>	

**Optional Accessories** (continues)

		Micro-Diesel Filter for Micro-Particles Filtration Automatic Fuel Refilling System Fuel Water Separator <b>(2000/40)</b> Mechanical Fuel Level Kit Oversize Fuel Tank Upon Custom Requirements Fuel Tanks-Pipes Heater Optional Built in fuel tank 180 L operation full load (Height will be increased by 100 mm and weight by 20 kg)
<b>Engine</b>	<b>Fuel</b>	
	<b>Air Inlet</b>	Sy-klone Air Cleaner Installed @ Air Intake System
	<b>Exhaust</b>	Muffler: Critical (25→30 dB) Hospital (35→40 dB) Elbow, Flanges, Expanders & Y Adaptors
	<b>Cooling / Heating</b>	Radiator with 35 °C or 60 °C Ambient Capability Jacket Water Heater
	<b>Lube</b>	Manual Sump Drain Pump Semi-Rotator Hand Pump
	<b>DC System - Starting/Changing</b>	Mains Battery Charger 24 V DC-5A Battery Charger 10A-20A on Request Automatic Battery Charger on Request Battery Disconnect Switch DC/AC Current Monitoring (Ammeter) Oversize Battery
<b>Control Panel</b>		DSE 7310/7320/7410/7420-More Inputs & Outputs-Advanced Communications Features; DSE 8610/8710/8810- Load Share Module; Digital & Analogues Inputs Module DSE 2130 (for 7000 Series & Above); Analogue Inputs advanced Module DSE 2131-2133(for 7410 &Above); Digital relay Outputs Module DSE 2157 (for 7000 Series &Above); Analogue Outputs Module DSE 2152 (for 7410 & Above); Local & Remote enunciator Module DSE 2548 (for 7000 Series & Above); Display Modules DSE 2510/2520 (with 7310-7320); Remote Monitoring via: Web Interface (All Series), GSM (for 7000 Series & Above), RS485 (for 7000 Dry Contacts Alarm Indication for Customer Use Audible Alarm (Option for 6010/20; Standard for 7000 Series & Above); Voltage Adjust Potentiometer; Speed Adjust Potentiometer;

**Dimensions & Weights**

	Length (mm)	Width (mm)	Height (mm)	Weight Dry
<b>Open set (NB)</b>	3850	1320	2277	6000
<b>SPC Type S</b>	5500	2100	2500	7900

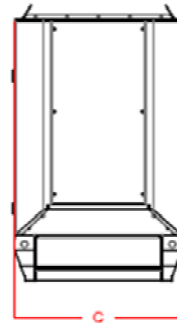
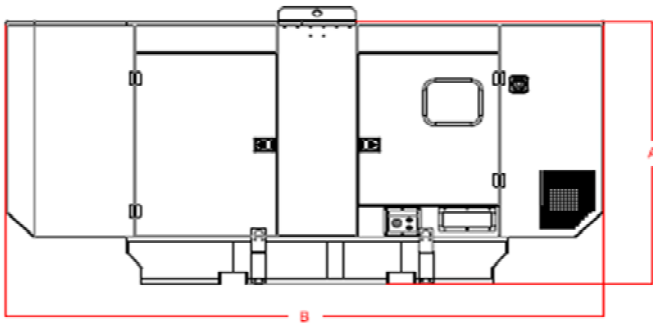
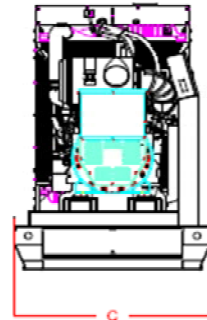
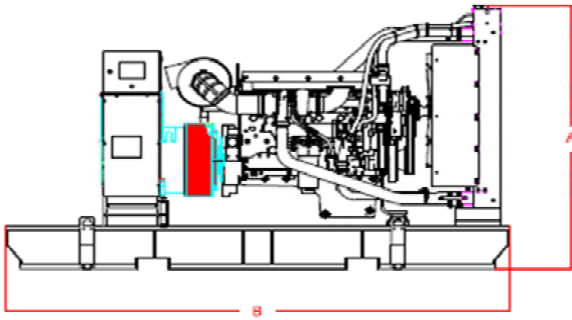

Drawings for illustration purposes only.

[WWW.METSENERGY.com](http://WWW.METSENERGY.com)